

# Alldrive 3 Tonne Hi-Swivel

## HYDROSTATIC

### Specifications

Dimensions (mm)	
A	3972
B	1770
C	2013
D	1600
E	1750
F	1979
G	280
H	1650
I	1130
J	1260
K	361
L	3440
M	2120
N	220
P	3140
R	4030
S	2240
T	2170
U	1850

Load over height: Skip down – 1395mm  
Skip up – 2000mm

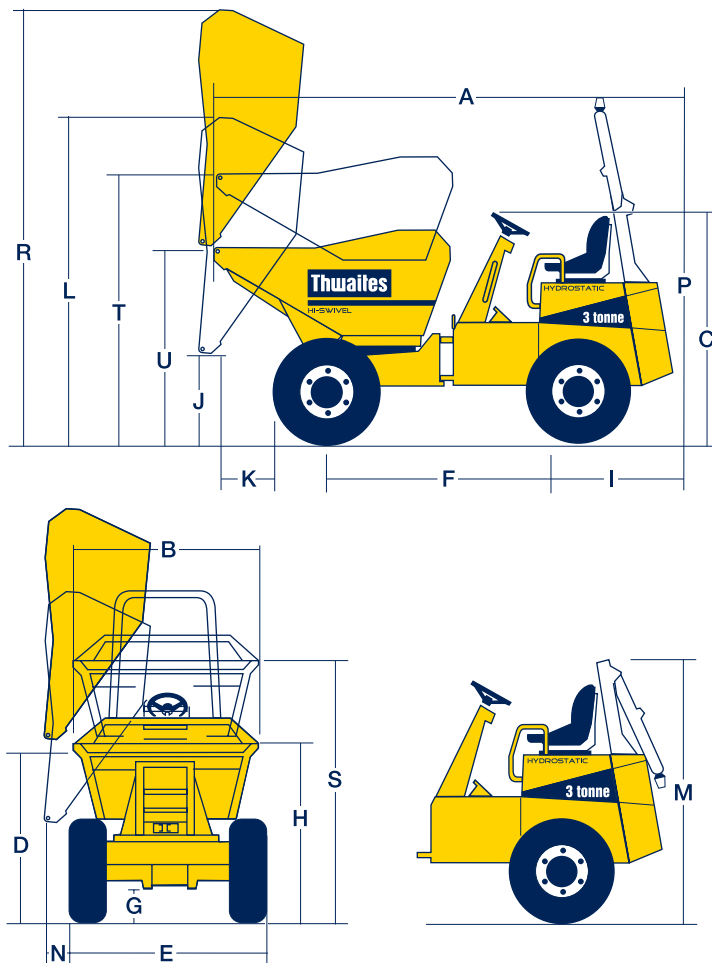

Model	Max. Safe Load Tonnes	Skip				Drive	Transmission	
		Front Tip	Powerswivel	Hi-Swivel	Hi-Tip		Powershuttle	Powershift
Alldrive 9	9	•				4x4	•	•
Alldrive 7	7	•				4x4	•	•
Alldrive 6	6	•	•			4x4	•	•
Alldrive 5	5	•	•			4x4	•	•
Alldrive 4.5	4.5	•	•			4x4	Hydrostatic	
Alldrive 4	4	•	•			4x4	Manual	
Alldrive 3.5	3.5	•	•	•*		4x4	Hydrostatic	
Alldrive 3	3	•	•	•		4x4	Manual	
Alldrive 2.3	2.3	•	•			4x4	Hydrostatic	
Alldrive 2	2	•	•			4x4	Manual/Hydrostatic	
Alldrive 1.5	1.5			•		4x4	Manual/Hydrostatic	
Alldrive 1	1		•		•	4x4	Hydrostatic	

\* 3 Tonne Max. safe load.

# Aldrive 3 Tonne Hi-Swivel

## HYDROSTATIC

### Specifications

<b>Capacities</b>	Max. safe load	3000 kg
	Heaped	1700 litres
	Struck	1300 litres
	Water	1050 litres

#### Engine

Yanmar 4TNV88, 33.4 kW/45 bhp (nett) at 2800 rpm, four-cylinder water-cooled direct-injection diesel. Max. torque 141 Nm (104 lbf ft). Electric starting. Hour meter, battery isolation switch and heavy-duty cyclonic air cleaner positioned within the lockable engine compartment.

#### Noise Levels

Operator's ear 84 LpA, airborne sound power level 104 LwA (to 2000/14/EC).

#### Transmission

Hydrostatic with high/low speed range and forward/reverse direction controlled by one column-mounted lever. Inching facility for precise manoeuvres in restricted areas activated by first push on brake pedal.

<b>Speeds</b>	Forward and reverse	
	Low	0–9.0 km/h ( 5.7 mph)
	High	0–24.0 km/h (15.1 mph)

<b>Tyres</b>	295/80 x 15.3
	10 ply
	Track-grip tread

#### Brakes and Axles

Totally enclosed multiplate oil-immersed discs mounted on rear axle effective on all four wheels. Automatic adjustment for wear. Hand-operated parking brake. Heavy-duty axles with epicyclic reduction and fully floating halfshafts. Reduction gearbox integral with rear axle differential housing.

#### Kinglink Chassis

Front and rear chassis constructed from deep section folded steel plate, with three-point Kinglink giving centre articulation and oscillation for better stability and traction, coupled with tight turning circle for outstanding manoeuvrability. Remote greasing point provided for lubrication of top Kinglink articulation pin.

#### Skips

Hydraulically operated, 5 mm steel plate all round, fully welded, mouth and sides of skip reinforced with box sections to minimise skip damage. Variable tipping height by means of a scissor lift. Two-lever control: one to raise and lower the scissor mechanism; the other, a dual-axis lever for rotating the skip through 180° and for discharging the load.

#### Seating & Controls

Adjustable suspension seat, accessible from both sides. Audible warning device at key start 'on' position and also when handbrake applied. Electric horn. Super-bright warning lights for all critical functions. Large pedal pads, with handbrake and hydraulic controls ready to hand.

#### Service Access

Lockable three-sided cover opens to provide easy access from ground level to engine service points, all located on the same side. Rear chassis panel can be hinged back on retainers. Additional service access door incorporates the battery. Moulded diesel and hydraulic tanks positioned low in the chassis side members, permitting access to the filler caps from ground level.

#### Electrics

Wiring harness contained within conduits and all electrical components water resistant to IP65/67 standards.

#### Steering & Hydraulics

Hydraulic power steering. Return line filtration for all services and large capacity suction strainer in the tank to give full circuit protection. Hydraulic test point fitted as standard.

<b>Tank capacities</b>	Fuel	45 litres
	Hydraulic	45 litres

<b>Shipping Cube</b>	14.2 m <sup>3</sup> (without ROPS)
----------------------	------------------------------------

<b>Unladen Weight</b>	2880 kg
-----------------------	---------

<b>Clearance Diameter</b>	under 8 m
---------------------------	-----------

<b>Towing Bracket</b>	Standard
-----------------------	----------

#### ROPS

For the UK and other markets where it is a legal requirement, a fully approved ROPS frame fitted as standard.

#### Optional Extras

Folding ROPS frame, ROPS/FOPS frame and canopy. Beacon. Full road lighting equipment. UK road equipment. Anti-theft device.

Distributor



We reserve the right to change all specifications without prior notice.  
Printed in England 04/2005.

# Thwaites

Thwaites Ltd. Leamington Spa, Warwickshire CV32 7NQ, England  
Tel: +44 (0)1926 422471 Fax: +44 (0)1926 337155  
www.thwaitesdumpers.co.uk